

Meraki MR62/66

Hardware Installation Guide

Trademarks

Meraki, Meraki MR62, MR66, and Meraki Cloud Controller are trademarks of Meraki, Inc. Other brand and product names are registered trademarks or trademarks of their respective holders.

Warranty

Meraki, Inc. provides a one year warranty on this product. Warranty details may be found at www.meraki.com/support.

Table of Contents

1	Scope of Document and Related Publications	4
2	MR66 Overview	5
	2.1 Package Contents	5
	2.2 Understanding the MR66	6
	2.3 Antennas and Ports	8
	2.4 Power Source Options	9
	2.5 Factory Reset Button	9
	2.6 LED Indicators and Run Dark Mode	9
3	Pre-Install Preparation	10
	3.1 Configure Your Network in Dashboard	10
	3.2 Check and Upgrade Firmware	10
	3.3 Check and Configure Firewall Settings	10
	3.4 Assigning IP Addresses to MR66s	11
	3.4.1 Dynamic Assignment	11
	3.4.2 Static Assignment	11
	3.5 Collect Tools	12
	3.6 Collect Additional Hardware for Installation	12
4	Installation Instructions	13
	4.1 Choose Your Mounting Location	13
	4.2 Install the MR66	13
	4.2.1 Attach the Mount Plate	14
	4.2.3 Mount the MR66	16
	4.2.3.1 Attach Antennas	17
	4.2.3.2 Aim Antennas	17
	4.2.3.3 Powering the MR66 with Meraki 802.3af Power over Ethernet Injector	18
	4.2.3.4 Powering the MR66 with an 802.3af Power over Ethernet Switch	18
	4.2.3.5 Attach Power over Ethernet to the MR66	19
	4.2.3.6 Attach Grounding Strap	20
	4.4 Verify Device Functionality and Test Network Coverage	21
5	Troubleshooting	21
6	Regulatory Information	22

1 Scope of Document and Related Publications

The MR62/66 Hardware Installation Guide describes the installation procedure for the MR62 and MR66 access points.

Note: All instructions in this hardware installation guide reference the MR66 but apply equally to the MR62, except where noted.

Additional reference documents are available online at meraki.com/support/#documentation.

2 MR66 Overview

The Meraki MR66 is an enterprise-class, 802.11n access point designed for rugged environments. When connected to the Meraki Cloud Controller, the MR66 enables the creation of high-speed and reliable networks that cover large outdoor and industrial areas quickly, easily, and cost-effectively.

2.1 Package Contents

The MR66 package contains the following:

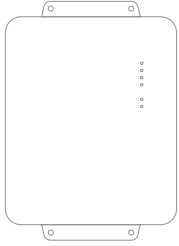

MR66 access point

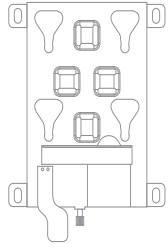

Mounting plate

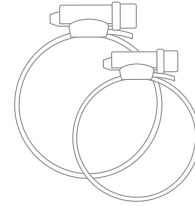

Mounting straps



Wall screws
& anchors



Cable gland

2.2 Understanding the MR66

Your Meraki MR66 has the following features:

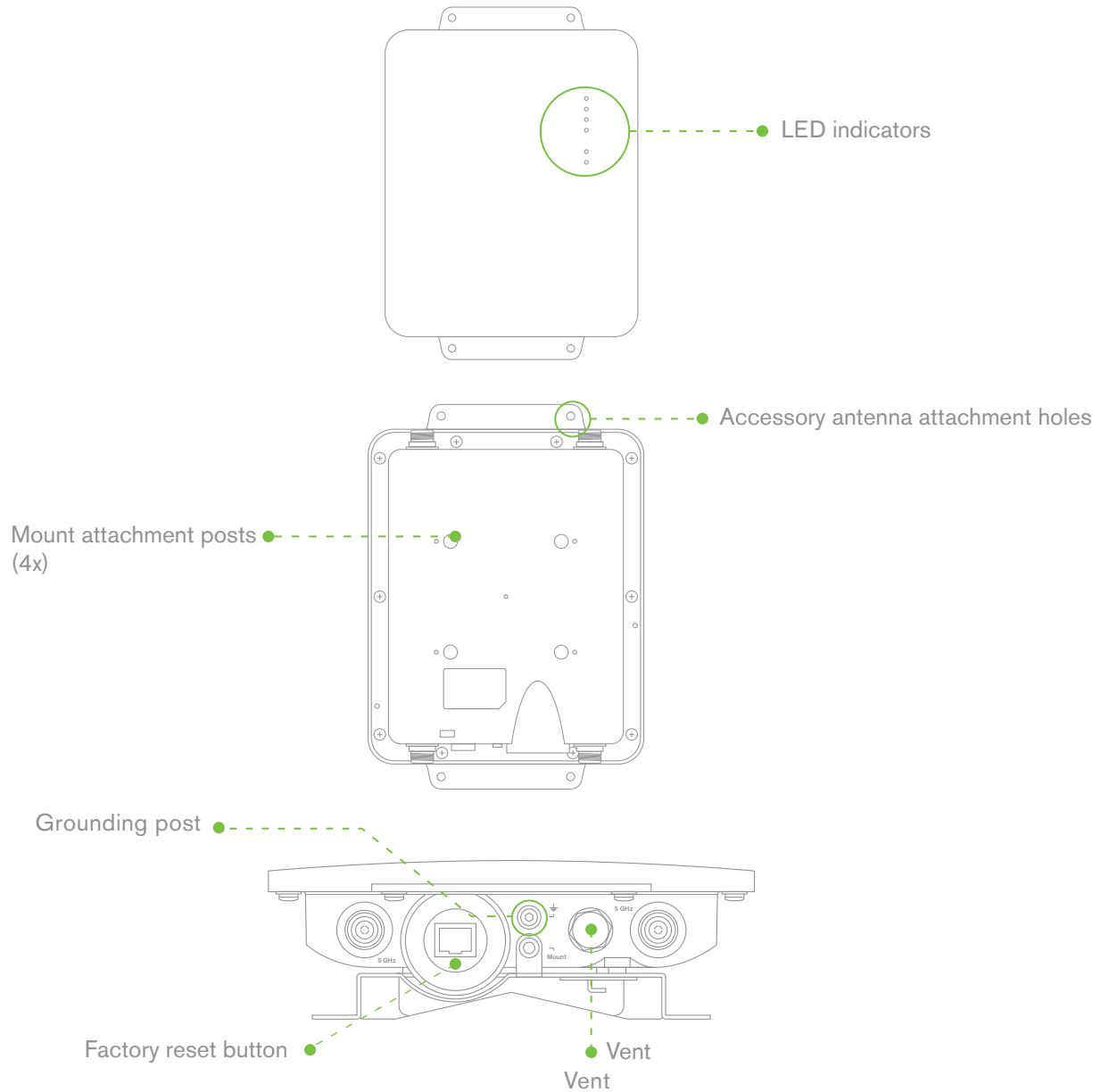

Vent

The vent allows pressure and humidity equalization between the interior and the environment. This prevents internal condensation and maintains a water proof seal.

Grounding Post

Provides an attachment point on the access point for the grounding strap (included). This post is threaded to accept a M4 x 0.7mm bolt

Your MR66 mount plate has the following features:

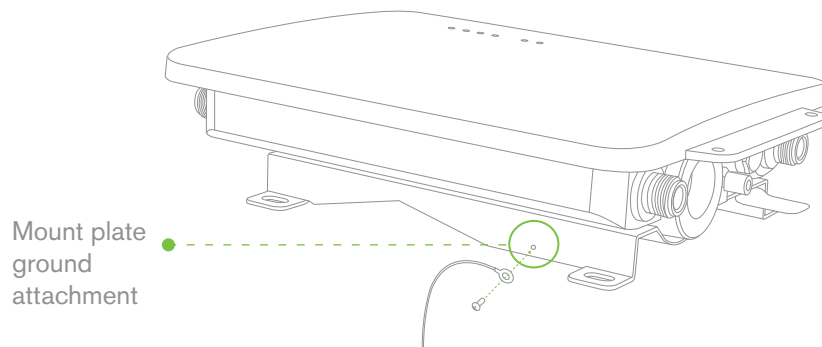
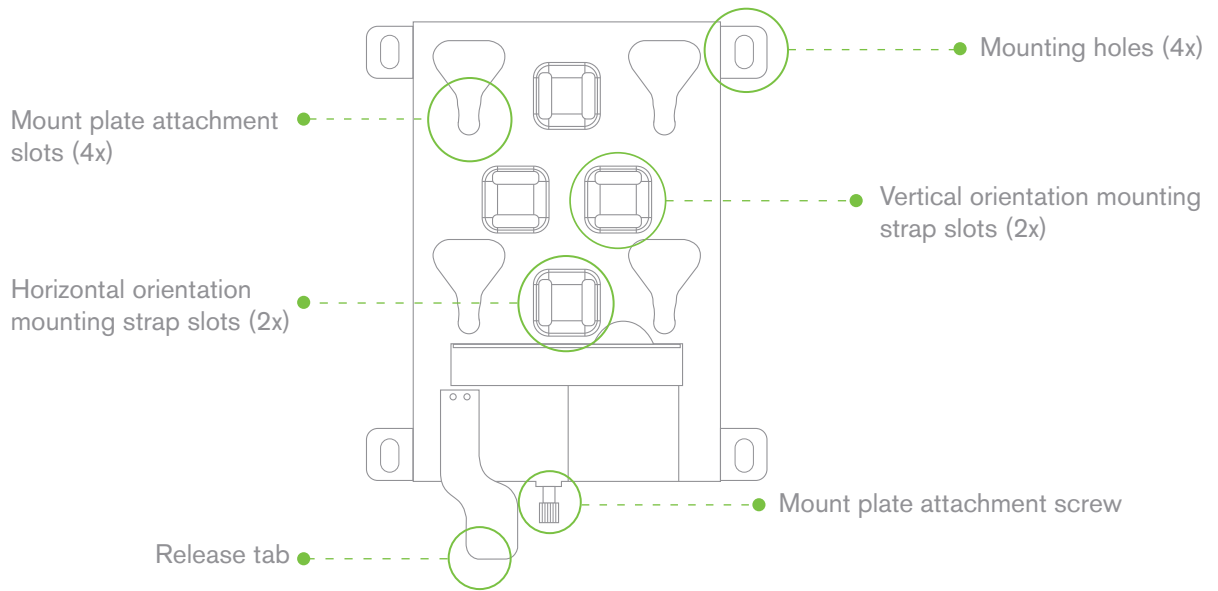

2.3 Antennas and Ports

The Meraki MR66 has two 802.11n radios (the MR62 has one radio). Each radio has two external antenna connectors; both connectors for a particular radio should be attached to the same type of antenna. The 5 GHz radio is used for mesh or client communication. The 2.4 GHz radio is primarily used for client communication. However, it can also communicate with Meraki 2.4 GHz access points.

Meraki offers a number of different antennas for use with the MR66. Alternately, you may purchase 3rd party antennas for use with the MR66. Make sure they have N-type connectors and support the proper frequency band (2.4 GHz or 5 GHz).

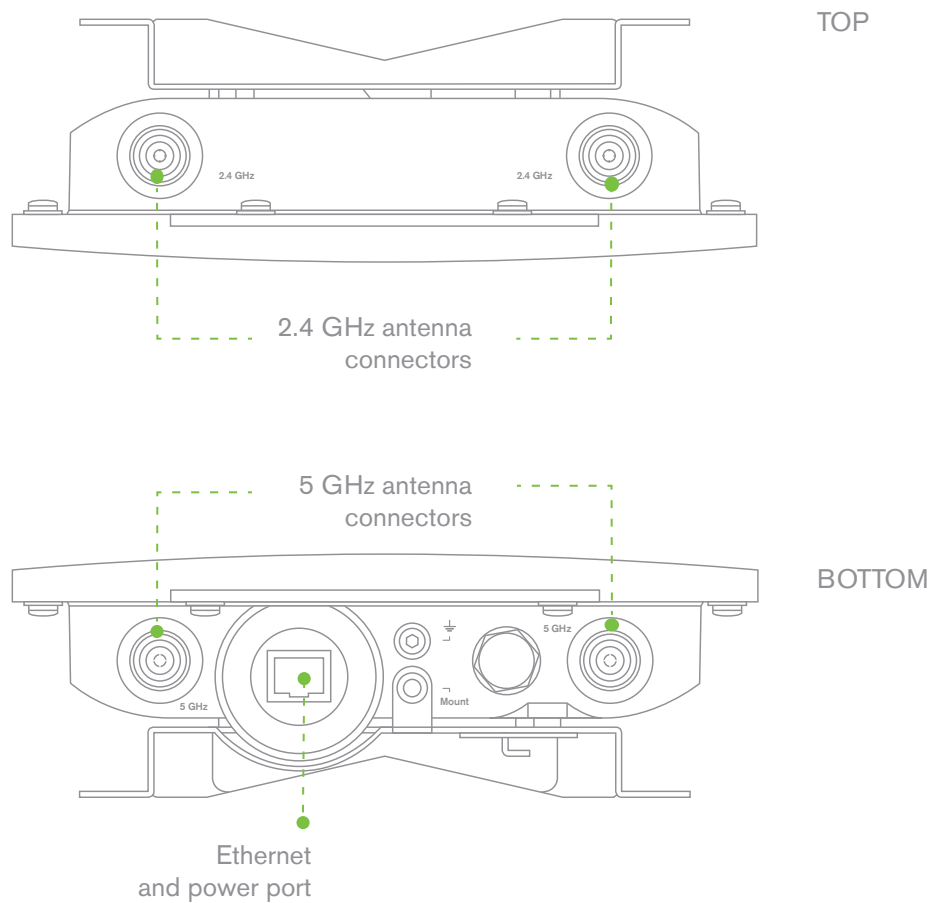

2.4 Power Source Options

The MR66 access point can be powered using either a third-party 802.3af PoE switch or the Meraki 802.3af PoE injector (sold separately).

2.5 Factory Reset Button

The Factory Reset Button restores the MR66 to its original factory settings by deleting all configuration information stored on the unit.

2.6 LED Indicators and Run Dark Mode

Your MR66 is equipped with a series of LED lights on the front of the unit to convey information about system functionality and performance.

●	☰	Signal Strength	
●		One Light:	Fair
☰	●	Four Lights:	Strongest
●		Moving Lights:	Searching for Signal
●		Flashing Lights:	Error state. May indicate bad gateway or other routing fault
↔ ●	⏻	Radio Power	
⏻ ●		Off:	MR66 is off
		Solid Orange:	MR66 is booting or trying to find a path to the internet
		Solid Green:	MR66 is fully operational and connected to the network
		Flashing Orange:	Firmware is upgrading
		Flashing Green:	Error state. May indicate bad gateway or other routing fault
	↔	Ethernet	
		Off:	No active network connection at the Ethernet port
		On:	Active network connection at the Ethernet port
		Flashing:	Error state. May indicate bad gateway or other routing fault

The MR66 may be operated in “Run Dark” mode for additional security and to reduce the visibility of the access point. In this mode, the LEDs will not be illuminated. This mode may be enabled through Meraki Dashboard.

3 Pre-Install Preparation

You should complete the following steps before going on-site to perform an installation.

3.1 Configure Your Network in Dashboard

Meraki recommends that you add your MR66 to a network in Dashboard before mounting it in the field. The following is a brief overview only of the steps required to add an MR66 to your network. For detailed instructions about creating, configuring and managing Meraki wireless networks, refer to the Meraki Cloud Controller Manual (meraki.com/support/#documentation).

1. Login to <http://dashboard.meraki.com>. If this is your first time, create a new account.
2. Find the network to which you plan to add your nodes or create a new network.
3. Add your nodes to your network. You will need your Meraki order number (found on your invoice if you ordered directly from Meraki) or the serial number of each node, which looks like Qxxx-xxxx-xxxx, and is found on the bottom of the unit.
4. Finally, go to the map / floor plan view and place each node on the map by clicking and dragging it to the location where you plan to mount it. You can always modify the location later.

3.2 Check and Upgrade Firmware

To ensure your MR66 performs optimally immediately following installation, Meraki recommends that you facilitate a firmware upgrade prior to mounting your MR66.

1. Attach your MR66 to power and a wired Internet connection. See p. 17 of this document for details.
2. The MR66 will turn on and the Power LED will glow solid orange. If the unit does not require a firmware upgrade, the Power LED will turn green within thirty seconds.

* If the unit requires an upgrade, the Power LED will begin blinking orange until the upgrade is complete, at which point the Power LED will turn solid green. You should allow about an hour for the firmware upgrade to complete, depending on the speed of your internet connection.

3.3 Check and Configure Firewall Settings

If your network will be located behind a firewall, it must allow outgoing connections on particular ports to particular IP addresses in order for the MR66 to be able to seamlessly communicate with the Cloud Controller. The most current list of outbound ports and IP addresses can be found here:

<http://tinyurl.com/y79une3>

3.4 Assigning IP Addresses to MR66s

All gateway MR66s (MR66s with Ethernet connections to the LAN) must be assigned routable IP addresses. These IP addresses can be dynamically assigned via DHCP or statically assigned.

3.4.1 Dynamic Assignment

When using DHCP, the DHCP server should be configured to assign a static IP address for each MAC address belonging to a Meraki AP. Other features of the wireless network, such as 802.1X authentication, may rely on the property that the APs have static IP addresses.

3.4.2 Static Assignment

Static IPs are assigned using the local web server on each AP. The following procedure describes how to set the static IP:

1. Using a client machine (e.g., a laptop), connect to the AP either wirelessly (by associating to any SSID broadcast by the AP) or over a wired connection.

If using a wired connection, connect the client machine to the MR66 either through a PoE switch or a Meraki PoE Injector. If using a PoE switch, plug an Ethernet cable into the MR66's Ethernet jack, and the other end into a PoE switch. Then connect the client machine over Ethernet cable to the PoE switch. If using a Meraki PoE Injector, connect the MR66 to the "PoE" port of the Injector, and the client machine to the "LAN" port.

2. Using a web browser on the client machine, access the AP's built-in web server by browsing to <http://my.meraki.com>. Alternatively, browse to <http://10.128.128.128>.
3. Click on the "Static IP Configuration" tab. Log in. The default user name is "admin". The default password is the AP's serial number, with hyphens included (e.g., Q2BD-551C-ZYW3).
4. Configure the static IP address, net mask, gateway IP address and DNS servers that this AP will use on its wired connection.
5. If necessary, reconnect the AP to the LAN.

3.5 Collect Tools

You will need the following tools to perform an installation:

Required



Straight-slot screwdriver

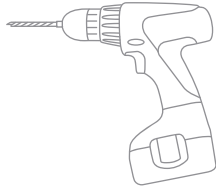

Drill with appropriate bits for mounting wall anchors (if mounting to a wall)



Phillips screwdriver

Recommended

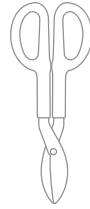

Tin snips (if mounting with hose clamps)

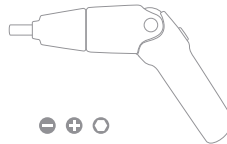

Power screwdriver with 5/16" (8 mm) nut driver, Phillips & flat heads

3.6 Collect Additional Hardware for Installation

Required

Network cables with RJ45 connectors long enough for your particular mounting location

802.3af PoE power source (either PoE switch or Meraki 802.3af PoE Injector)

Connection to the internet (if you are setting up your MR66 as a gateway to the internet)

Appropriately sized metal straps (if mounting to a pole larger than 3.9" in diameter)

Specialized mounting hardware if mounting to surface other than wood, stucco or stone

Recommended

Laptop with wireless to verify setup

4 Installation Instructions

4.1 Choose Your Mounting Location

A good mounting location is important to getting the best performance out of your MR66 access point. Keep the following in mind:

1. The device should have unobstructed line of sight to most coverage areas. For example, if installing in an office filled with workspaces divided by mid-height cubicle walls, installing on the ceiling or high on a wall would be ideal.
2. Power over Ethernet supports a maximum cable length of 300 ft (100 m).
3. If being used in a mesh deployment, the MR66 should have line of sight to at least two other Meraki devices. For more detailed instructions regarding access point location selection, reference the Meraki Network Design Guide (meraki.com/support/#documentation).
4. The antennas should be as unobstructed as possible. Make sure that there is clearance around the MR66 for installation of all of your chosen antennas.

4.2 Install the MR66

For most mounting scenarios, the MR66 mount plate provides a quick, simple, and flexible means of mounting your device. The installation should be done in two steps. First, install the mount plate to your selected location. Then attach the MR66 to the mount plate.

4.2.1 Remove the Mount Plate from the Access Point

Before installing the mount plate, you must remove it from the back of the access point.

1. Unscrew the mount plate attachment screw.
2. Lift and the mount plate release tab upwards.
3. While holding the mount plate release tab up, slide the mount plate off the access point in the direction shown below.

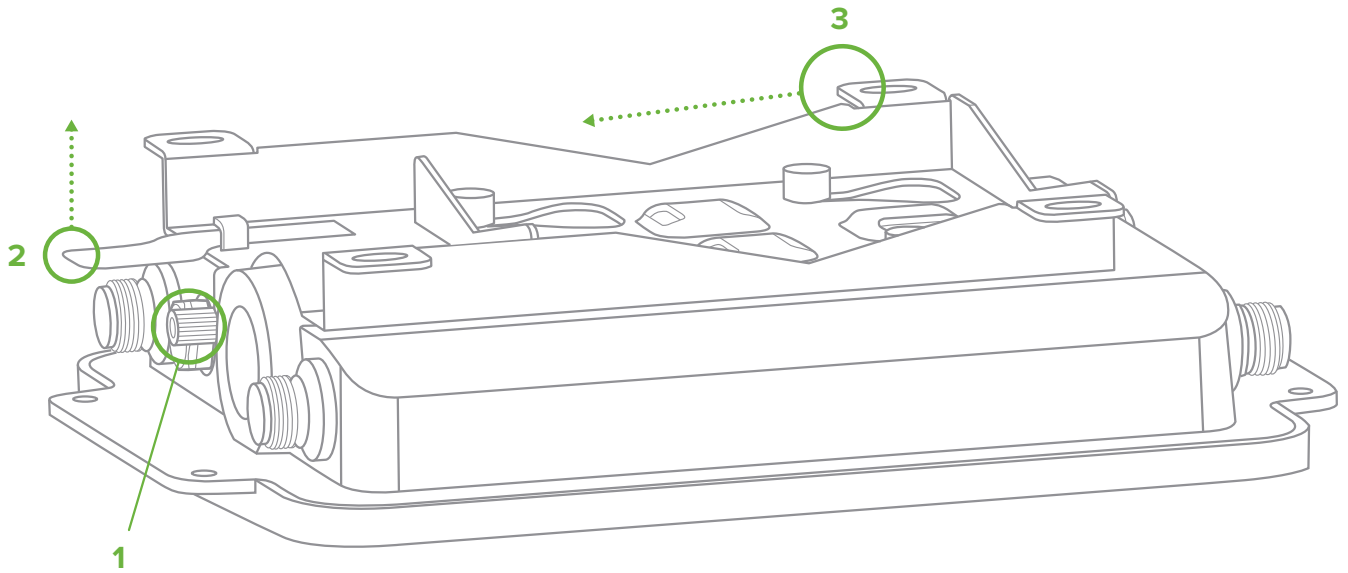

4.2.2 Attach the Mount Plate

The MR66 mount plate can be used to install your access point in a wide range of scenarios.

4.2.2.1 Wall or Solid Ceiling Mount Using Mount Plate

Using included wall anchors and screws, attach the mount plate to your mounting wall or ceiling.

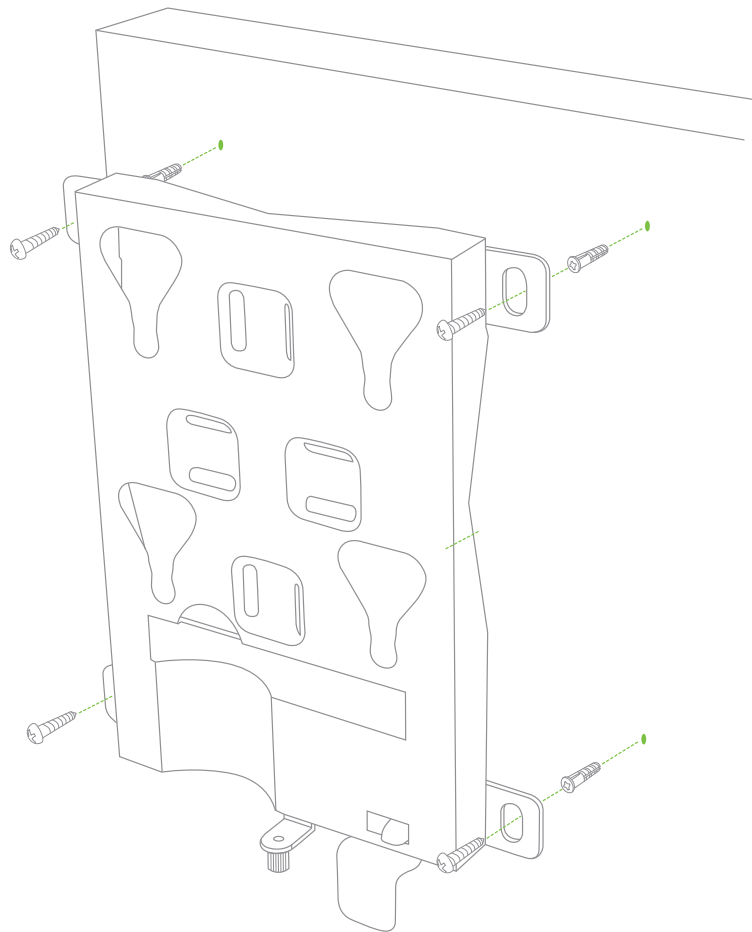

It is recommended that the MR66 be mounted to a wall or solid ceiling using the mount plate for physical security reasons.

4.2.3 Mount the MR66

Insert the posts on the back of the access point into the attachment slots on the mount plate.

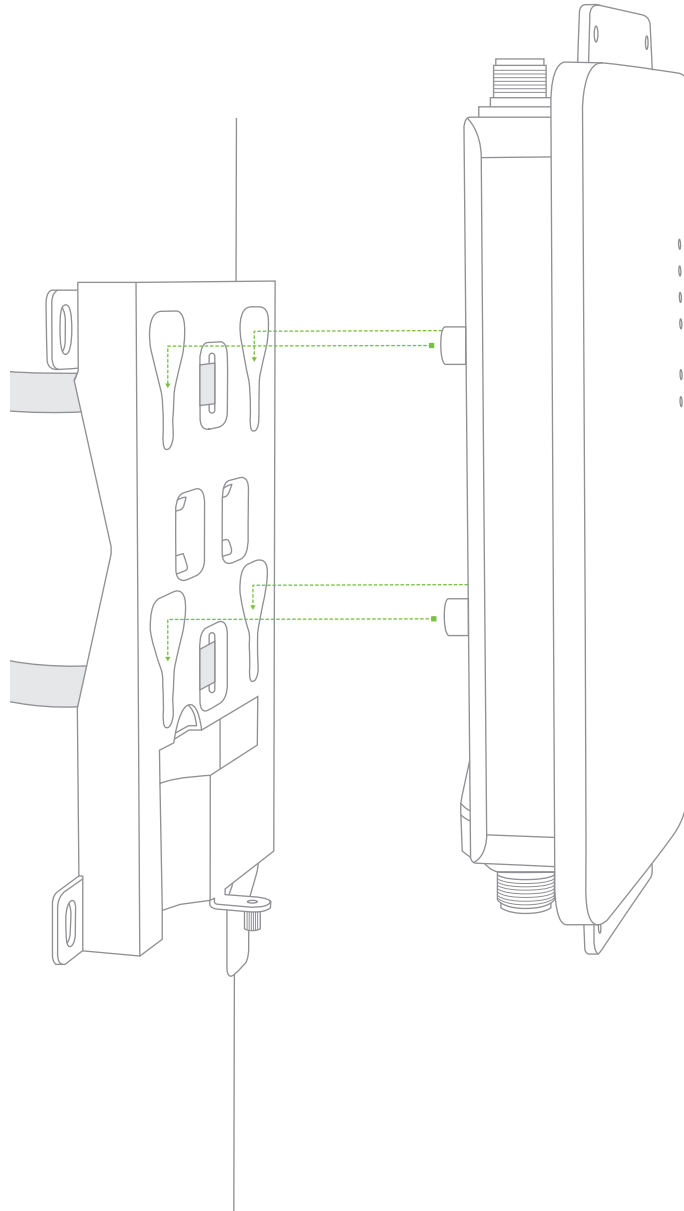

4.2.3.1 Attach Antennas

Remove protective plastic covers from all four N-type RF connectors. Attach appropriate antennas (and protective boots if included).

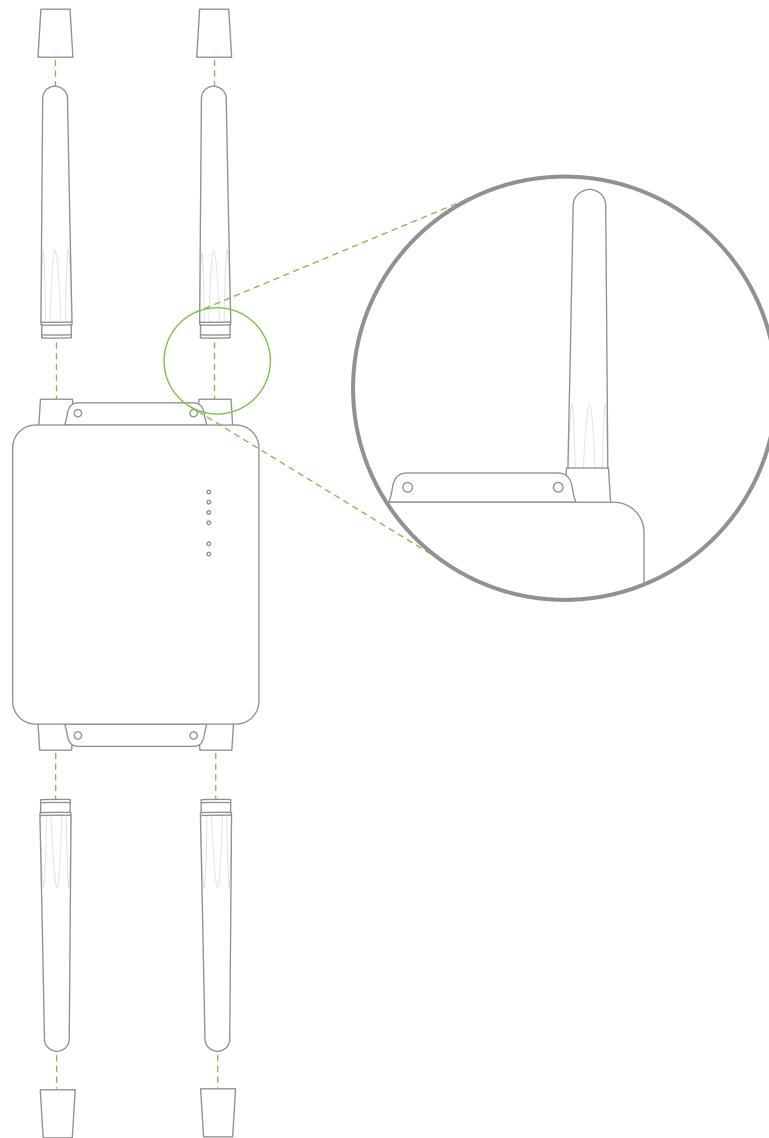

4.2.3.2 Aim Antennas

If you are using directional antennas, aim them appropriately to ensure optimal performance for your specific network topography. Omnidirectional antennas perform best in a mesh network when oriented vertically.

4.2.3.3 Powering the MR66 with the Meraki 802.3af Power over Ethernet Injector (sold separately)

1. Plug the power cord into the PoE Injector and the other end into wall power.
2. Plug an Ethernet cable that is connected to an active Ethernet connection into the "IN" port on the injector.
3. Route Ethernet cable from the "OUT" port on the injector to the Ethernet port in the bay of the MR66.

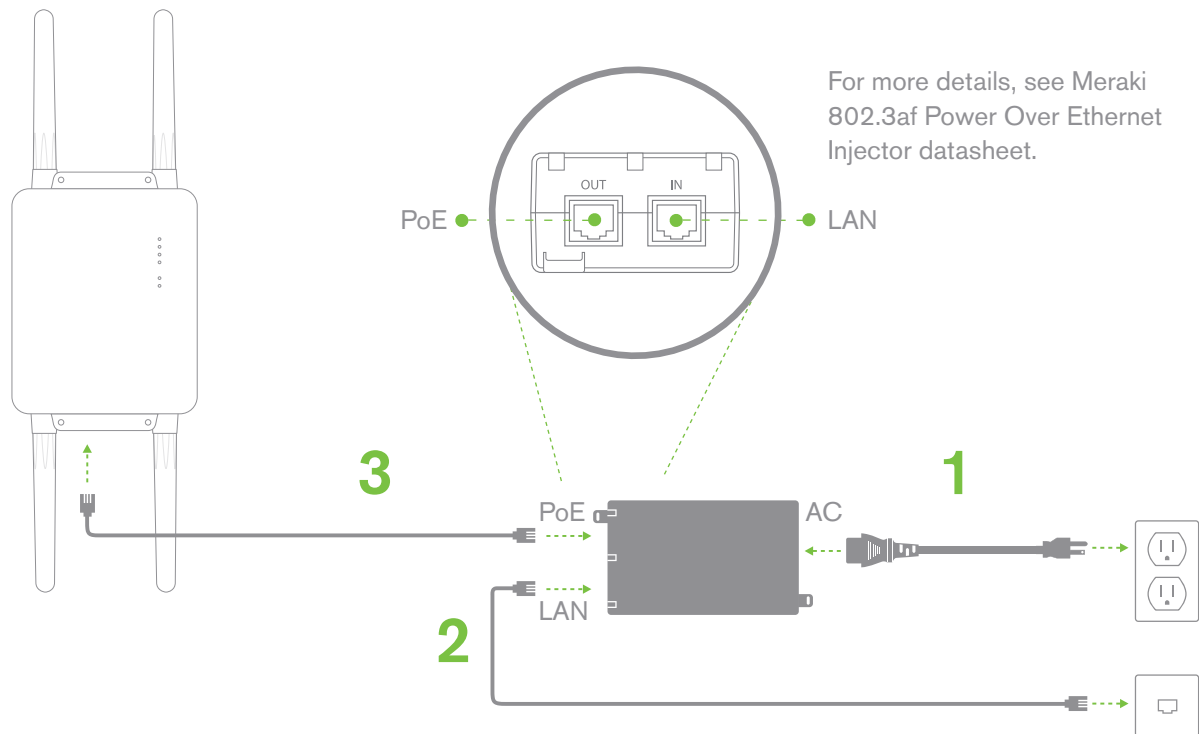

4.2.3.4 Powering the MR66 with an 802.3af Power over Ethernet Switch

Route Ethernet cable from a port on an active 802.3af PoE switch to the Ethernet port in the bay of the MR66.

! The MR66 is Gigabit Ethernet-capable. To maximize device performance, a Gigabit Ethernet-capable switch should be used.

4.2.3.5 Attach Power over Ethernet to the MR66

1. Route the Ethernet cable from the PoE Injector "OUT" port to the MR66.
2. Install a cable gland on the MR66 end of the cable.

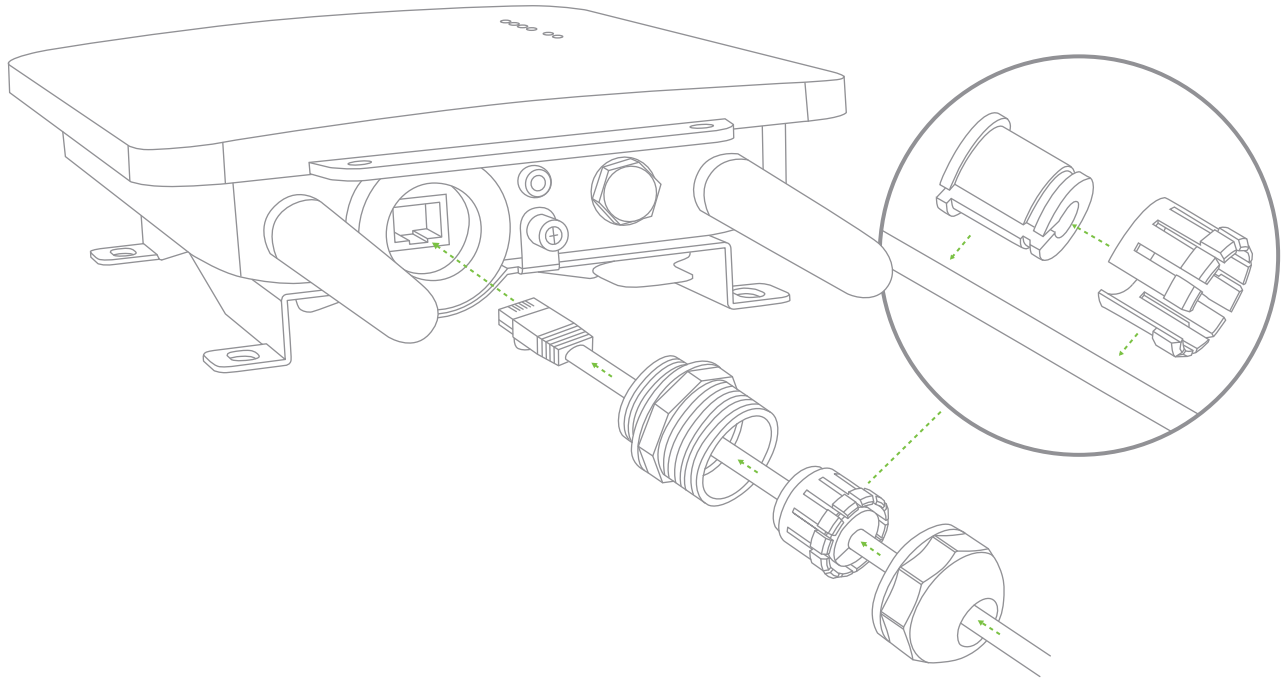

4. Plug the Ethernet cable into the Ethernet port of the Meraki MR66.
 - a. Connect the cable to the Ethernet port on the MR66.
 - b. Screw the gland body into the threaded hole of the port. Use an adjustable wrench to make sure the gland body is fully seated in the hole.
 - c. Insert the split ring gasket into the gland body.
 - d. Screw the cap tightly onto the gland. You may need a wrench to fully tighten the cap, but take care not to damage the cable in the process.

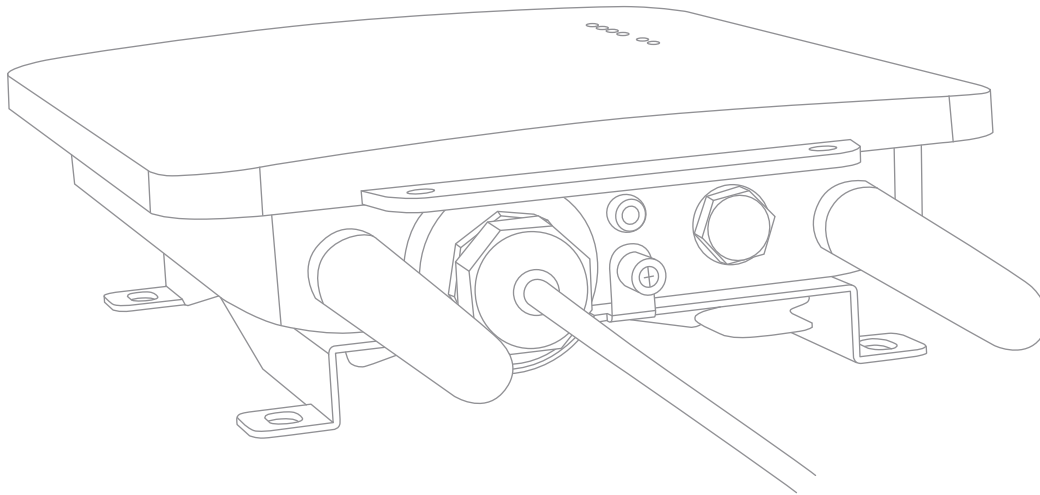

Optional: Make the MR66 a gateway

1. Connect an active internet connection to the “IN” port of the PoE injector.

4.2.3.6 Attach Grounding Strap

Connect one end of grounding strap to grounding post with included screw and washer. Securely attach the other end nearby grounded structure.

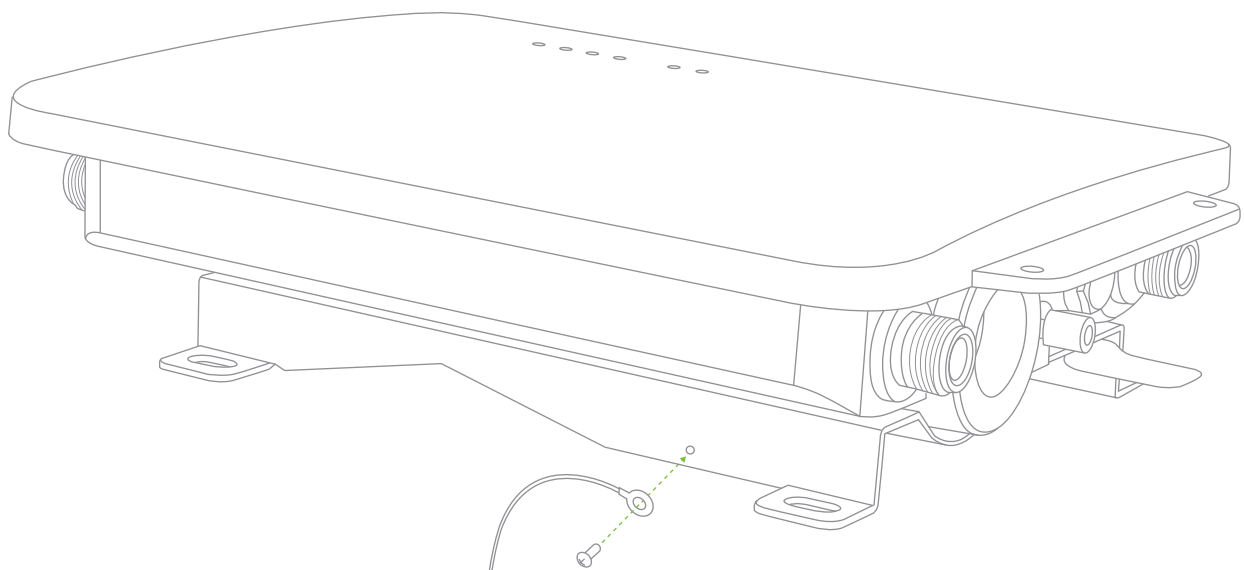

Connect to
grounded structure

4.4 Verify Device Functionality and Test Network Coverage

1. Check LEDs

The Radio Power LED should be solid green. If it is flashing orange, the firmware is automatically upgrading and the LED should turn green when the upgrade is completed (normally in under thirty minutes). If the device is a gateway, the Ethernet LED and the four Signal Strength LEDs should be green as well. If the device is a repeater only, the Ethernet LED will not be illuminated and the number of green Signal Strength LEDs will show the signal strength to the nearest Meraki device. See section 2.6 for further details about information conveyed by the LEDs.

Note: Your MR66 must have an active route to the Internet to check and upgrade its firmware.

2. Verify access point connectivity

Use any 802.11 client device to connect to the MR66 and verify proper connectivity using the client's web browser.

3. Check network coverage

Confirm that you have good signal strength throughout your coverage area. You can use the signal strength meter on a laptop, smart phone, or other wireless device.

5 Troubleshooting

Reference the Meraki knowledge base at <http://meraki.com/support/#kb> for additional information and troubleshooting tips.

6 Regulatory Information for MR62

U.S. Regulatory Wireless Notice

Federal Communication Commission Interference Statement:

This equipment has been tested and found to comply with the limits for a Class B digital device, pursuant to Part 15 of the FCC Rules. These limits are designed to provide reasonable protection against harmful interference in a residential installation. This equipment generates, uses and can radiate radio frequency energy and, if not installed and used in accordance with the instructions, may cause harmful interference to radio communications. However, there is no guarantee that interference will not occur in a particular installation. If this equipment does cause harmful interference to radio or television reception, which can be determined by turning the equipment off and on, the user is encouraged to try to correct the interference by one of the following measures:

- Reorient or relocate the receiving antenna.
- Increase the separation between the equipment and receiver.
- Connect the equipment into an outlet on a circuit different from that to which the receiver is connected.
- Consult the dealer or an experienced radio/TV technician for help.

FCC Caution:

Any changes or modifications not expressly approved by the party responsible for compliance could void the user's authority to operate this equipment.

This device complies with Part 15 of the FCC Rules. Operation is subject to the following two conditions:

- this device may not cause harmful interference, and
- this device must accept any interference received, including interference that may cause undesired operation.

FCC Radiation Exposure Statement:

This equipment complies with FCC radiation exposure limits set forth for an uncontrolled environment. This equipment should be installed and operated with minimum distance 50 cm between the radiator and your body. This transmitter must not be co-located or operating in conjunction with any other antenna or transmitter.

IEEE 802.11b or 802.11g operation of this product in the USA is firmware-limited to channels 1 through 11.

Canadian Regulatory Wireless Notice

This device complies with RSS-210 of the Industry Canada Rules. Operation is subject to the following two conditions:

- this device may not cause interference and
- this device must accept any interference received, including interference that may cause undesired operation

Ce dispositif est conforme à la norme CNR-210 d'Industrie Canada applicable aux appareils radio exempts de licence. Son fonctionnement est sujet aux deux conditions suivantes:

- le dispositif ne doit pas produire de brouillage préjudiciable, et
- ce dispositif doit accepter tout brouillage reçu, y compris un brouillage susceptible de provoquer un fonctionnement indésirable.

IC Radiation Exposure Statement:

This equipment complies with IC radiation exposure limits set forth for an uncontrolled environment. This equipment should be installed and operated with minimum distance 50 cm between the radiator and your body.

This device has been designed to operate with an antenna having a maximum gain of 11dBi. Antenna having a higher gain is strictly prohibited per regulations of Industry Canada. The required antenna impedance is 50 ohms.

Déclaration d'exposition aux radiations:

Cet équipement est conforme aux limites d'exposition aux rayonnements IC établies pour un environnement non contrôlé. Cet équipement doit être installé et utilisé avec un minimum de 50cm de distance entre la source de rayonnement et votre corps.

Ce dispositif a été conçu pour fonctionner avec une antenne ayant un gain maximal de 11dBi. Une antenne à gain plus élevé est strictement interdite par les règlements d'Industrie Canada. L'impédance d'antenne requise est de 50 ohms.

This radio transmitter (IC: 6961A-60018010 / Model: 600-18010) has been approved by Industry Canada to operate with the antenna types listed below with the maximum permissible gain and required antenna impedance for each antenna type indicated. Antenna types not included in this list, having a gain greater than the maximum gain indicated for that type, are strictly prohibited for use with this device.

Le présent émetteur radio (IC: 6961A-60018010 / Model: 600-18010) a été approuvé par Industrie Canada pour fonctionner avec les types d'antenne énumérés ci-dessous et ayant un gain admissible maximal et l'impédance requise pour chaque type d'antenne. Les types d'antenne non inclus dans cette liste, ou dont le gain est supérieur au gain maximal indiqué, sont strictement interdits pour l'exploitation de l'émetteur.

Remark :

Antenna Information :

Omni ANT 2.4GHz : 5dBi

Sector ANT 2.4GHz : 11dBi

Europe – EU Declaration of Conformity

This device complies with the essential requirements of the R&TTE Directive 1999/5/EC.

The following test methods have been applied in order to prove presumption of conformity with the essential requirements of the R&TTE Directive 1999/5/EC:

Radio:	EN 300 328, EN 301 893
EMC:	EN 301 489-1, EN 301 489-17
Safety:	EN 60950-1
RF Exposure:	EN 50385
Emissions:	EN 55022, EN 61000-3-2, EN 61000-3-3
Immunity:	EN 61000-4-2, EN 61000-4-3, EN 61000-4-4, EN 61000-4-5, EN 61000-4-6, EN 61000-4-11

This device is a 2.4 GHz wideband transmission system (transceiver), intended for use in all EU member states and EFTA countries with the following restrictions:

In Italy the end-user should apply for a license at the national spectrum authorities in order to obtain authorization to use the device for setting up outdoor radio links and/or for supplying public access to telecommunications and/or network services.

Česky (Czech)

Meraki, Inc. tímto prohlašuje, že tento wireless device je ve shodě se základními požadavky a dalšími příslušnými ustanoveními směrnice.

Dansk (Danish)

Undertegnede Meraki, Inc. erklærer herved, at følgende udstyr wireless device overholder de væsentlige krav og øvrige relevante krav i direktiv 1999/5/EF.

Deutsch (German)

Hiermit erklärt Meraki, Inc., dass sich das Gerät wireless device in Übereinstimmung mit den grundlegenden Anforderungen und den übrigen einschlägigen Bestimmungen der Richtlinie 1999/5/EG befindet.

Eesti (Estonian)

Käesolevaga kinnitab Meraki, Inc. seadme wireless device vastavust direktiivi 1999/5/EÜ põhinõuetele ja nimetatud direktiivist tulenevatele.

English

Hereby, Meraki, Inc., declares that this wireless device is in compliance with the essential requirements and other relevant provisions of Directive 1999/5/EC.

Español (Spanish)

Por medio de la presente Meraki, Inc. declara que el wireless device cumple con los requisitos esenciales y cualesquiera otras disposiciones aplicables o exigibles de la Directiva 1999/5/CE.

Ελληνική (Greek)

ΜΕ ΤΗΝ ΠΑΡΟΥΣΑ Meraki, Inc. ΔΗΛΩΝΕΙ ΟΤΙ wireless device ΣΥΜΜΟΡΦΩΝΕΤΑΙ ΠΡΟΣ ΤΙΣ ΟΥΣΙΩΔΕΙΣ ΑΠΑΙΤΗΣΕΙΣ ΚΑΙ ΤΙΣ ΛΟΙΠΕΣ ΣΧΕΤΙΚΕΣ ΔΙΑΤΑΞΕΙΣ ΤΗΣ ΟΔΗΓΙΑΣ 1999/5/ΕΚ.

Français (French)

Par la présente Meraki, Inc. déclare que l'appareil wireless device est conforme aux exigences essentielles et aux autres dispositions pertinentes de la directive 1999/5/CE.

Italiano (Italian)

Con la presente Meraki, Inc. dichiara che questo wireless device è conforme ai requisiti essenziali ed alle altre disposizioni pertinenti stabilite dalla direttiva 1999/5/CE.

Latviski (Latvian)

Ar šo Meraki, Inc. deklarē, ka wireless device atbilst Direktīvas 1999/5/EK būtiskajām prasībām un citiem ar to saistītajiem noteikumiem.

Lietuvių (Lithuanian)

Šiuo Meraki, Inc. deklaruoja, kad šis wireless device atitinka esminius reikalavimus ir kitas 1999/5/EB Direktyvos nuostatas.

Nederland (Dutch)

Hierbij verklaart Meraki, Inc. dat het toestel wireless device in overeenstemming is met de essentiële eisen en de andere relevante bepalingen van richtlijn 1999/5/EG.

Malti (Maltese)

Hawnhekk, Meraki, Inc., jiddikjara li dan wireless device jikkonforma mal-ħtigijiet essenzjali u ma provvedimenti oħrajn rilevanti li hemm fid-Dirrettiva 1999/5/EC.

Magyar (Hungarian)

Alulírott, Meraki, Inc. nyilatkozom, hogy a wireless device megfelel a vonatkozó alapvető követelményeknek és az 1999/5/EC irányelv egyéb előírásainak.

Polski (Polish)

Niniejszym Meraki, Inc. oświadcza, że wireless device jest zgodny z zasadniczymi wymogami oraz pozostałymi stosownymi

Português (Portuguese)

Meraki, Inc. declara que este wireless device está conforme com os requisitos essenciais e outras disposições da Directiva 1999/5/CE.

Slovensko (Slovenian)

Meraki, Inc. izjavlja, da je ta wireless device v skladu z bistvenimi zahtevami in ostalimi relevantnimi določili direktive 1999/5/ES.

Slovensky (Slovak)

Meraki, Inc. týmto vyhlasuje, že wireless device splna základné požiadavky a všetky príslušné ustanovenia Smernice 1999/5/ES.

Suomi (Finnish)

Meraki, Inc. vakuuttaa täten että wireless device tyyppinen laite on direktiivin 1999/5/EY oleellisten vaatimusten ja sitä koskevien direktiivin muiden ehtojen mukainen.

Svenska (Swedish)

Härmed intygar Meraki, Inc. att denna wireless device står i överensstämmelse med de väsentliga egenskapskrav och övriga relevanta bestämmelser som framgår direktiv 1995/5/EG.



Professional installation instruction

Please be advised that due to the unique function supplied by this product, the device is intended for use with our interactive entertainment software and licensed third-party only. The product will be distributed through controlled distribution channel and installed by trained professional and will not be sold directly to the general public through retail store.

1. Installation personal

This product is designed for specific application and needs to be installed by a qualified personal who has RF and related rule knowledge. The general user shall not attempt to install or change the setting.

2. Installation location

The product shall be installed at a location where the radiating antenna can be kept 50cm from nearby person in normal operation condition to meet regulatory RF exposure requirement.

3. External antenna

Use only the antennas which have been approved by Meraki Inc. The non-approved antenna(s) may produce unwanted spurious or excessive RF transmitting power which may lead to the violation of FCC/IC limit and is prohibited.

4. Installation procedure

Please refer to the rest of this manual for the detail.

5. Warning

Please carefully select the installation position and make sure that the final output power does not exceed the limit set force in relevant rules. The violation of the rule could lead to serious federal penalty.

The following maximum Transmit powers should be observed during configuration:

Omni antenna:

802.11b:	23.7 dBm
802.11g:	27.7 dBm
802.11n 20 M:	27.7 dBm
802.11n 40 M:	27.7 dBm

Panel antenna:

802.11b:	22.5 dBm
802.11g:	27.0 dBm
802.11n 20 M:	27.0 dBm
802.11n 40 M:	25.8 dBm

At these levels the panel antenna can be used only on point to point application. Point to multi-points is not allowed, and may require further reductions to meet local regulations.

Instructions d'installation professionnelle

Veillez noter que l'appareil étant dédié à une fonction unique, il doit être utilisé avec notre logiciel propriétaire de divertissement interactif. Ce produit sera proposé par un réseau de distribution contrôlé et installé par des professionnels; il ne sera pas proposé au grand public par le réseau de la grande distribution.

1. Installation

Ce produit est destiné à un usage spécifique et doit être installé par un personnel qualifié maîtrisant les radiofréquences et les règles s'y rapportant. L'installation et les réglages ne doivent pas être modifiés par l'utilisateur final.

2. Emplacement d'installation

En usage normal, afin de respecter les exigences réglementaires concernant l'exposition aux radiofréquences, ce produit doit être installé de façon à respecter une distance de 50 cm entre l'antenne émettrice et les personnes.

3. Antenne externe

Utiliser uniquement les antennes approuvées par le fabricant. L'utilisation d'autres antennes peut conduire à un niveau de rayonnement essentiel ou non essentiel dépassant les niveaux limites définis par FCC/IC, ce qui est interdit.

4. Procédure d'installation

Consulter le manuel d'utilisation.

5. Avertissement

Choisir avec soin la position d'installation et s'assurer que la puissance de sortie ne dépasse pas les limites en vigueur. La violation de cette règle peut conduire à de sérieuses pénalités fédérales.

7 Regulatory Information for MR66

U.S. Regulatory Wireless Notice

Federal Communication Commission Interference Statement:

This equipment has been tested and found to comply with the limits for a Class B digital device, pursuant to Part 15 of the FCC Rules. These limits are designed to provide reasonable protection against harmful interference in a residential installation. This equipment generates, uses and can radiate radio frequency energy and, if not installed and used in accordance with the instructions, may cause harmful interference to radio communications. However, there is no guarantee that interference will not occur in a particular installation. If this equipment does cause harmful interference to radio or television reception, which can be determined by turning the equipment off and on, the user is encouraged to try to correct the interference by one of the following measures:

- Reorient or relocate the receiving antenna.
- Increase the separation between the equipment and receiver.
- Connect the equipment into an outlet on a circuit different from that to which the receiver is connected.
- Consult the dealer or an experienced radio/TV technician for help.

FCC Caution:

Any changes or modifications not expressly approved by the party responsible for compliance could void the user's authority to operate this equipment.

This device complies with Part 15 of the FCC Rules. Operation is subject to the following two conditions:

- this device may not cause harmful interference, and
- this device must accept any interference received, including interference that may cause undesired operation.

FCC Radiation Exposure Statement:

This equipment complies with FCC radiation exposure limits set forth for an uncontrolled environment. This equipment should be installed and operated with minimum distance 30 cm between the radiator and your body. This transmitter must not be co-located or operating in conjunction with any other antenna or transmitter.

IEEE 802.11b or 802.11g operation of this product in the USA is firmware-limited to channels 1 through 11.

If this device is going to be operated in 5.15 ~ 5.25 GHz frequency range, then it is restricted in indoor environment only.

Canadian Regulatory Wireless Notice

This device complies with RSS-210 of the Industry Canada Rules. Operation is subject to the following two conditions:

- this device may not cause interference and
- this device must accept any interference, including interference that may cause undesired operation of the device.

Ce dispositif est conforme à la norme CNR-210 d'Industrie Canada applicable aux appareils radio exempts de licence. Son fonctionnement est sujet aux deux conditions suivantes:

- le dispositif ne doit pas produire de brouillage préjudiciable, et
- ce dispositif doit accepter tout brouillage reçu, y compris un brouillage susceptible de provoquer un fonctionnement indésirable.

IC Radiation Exposure Statement:

This equipment complies with IC radiation exposure limits set forth for an uncontrolled environment. This equipment should be installed and operated with minimum distance 30 cm between the radiator and your body.

This device has been designed to operate with an antenna having a maximum gain of 14 dBi. Antenna having a higher gain is strictly prohibited per regulations of Industry Canada. The required antenna impedance is 50 ohms.

Under Industry Canada regulations, this radio transmitter may only operate using an antenna of a type and maximum (or lesser) gain approved for the transmitter by Industry Canada. To reduce potential radio interference to other users, the antenna type and its gain should be so chosen that the equivalent isotropically radiated power (e.i.r.p.) is not more than that necessary for successful communication.

This radio transmitter (IC: 6961A-60019010 / Model: 600-19010) has been approved by Industry Canada to operate with the antenna types listed below with the maximum permissible gain and required antenna impedance for each antenna type indicated. Antenna types not included in this list, having a gain greater than the maximum gain indicated for that type, are strictly prohibited for use with this device.

Caution:

The device for the band 5150-5250 MHz is only for indoor usage to reduce potential for harmful interference to co-channel mobile satellite systems.

NOTE IMPORTANTE: (Pour l'utilisation de dispositifs mobiles)

Déclaration d'exposition aux radiations:

Cet équipement est conforme aux limites d'exposition aux rayonnements IC établies pour un environnement non contrôlé. Cet équipement doit être installé et utilisé avec un minimum de 30 cm de distance entre la source de rayonnement et votre corps

(Le manuel d'utilisation de dispositifs émetteurs équipés d'antennes amovibles doit contenir les informations suivantes dans un endroit bien en vue:)

Ce dispositif a été conçu pour fonctionner avec une antenne ayant un gain maximal de dBi 14. Une antenne à gain plus élevé est strictement interdite par les règlements d'Industrie Canada. L'impédance d'antenne requise est de 50 ohms. Conformément à la réglementation d'Industrie Canada, le présent émetteur radio peut fonctionner avec une antenne d'un

type et d'un gain maximal (ou inférieur) approuvé pour l'émetteur par Industrie Canada. Dans le but de réduire les risques de brouillage radioélectrique à l'intention des autres utilisateurs, il faut choisir le type d'antenne et son gain de sorte que la puissance isotrope rayonnée équivalente (p.i.r.e.) ne dépasse pas l'intensité nécessaire à l'établissement d'une communication satisfaisante.

Le présent émetteur radio (IC: 6961A-60019010 / Model: 600-19010) a été approuvé par Industrie Canada pour fonctionner avec les types d'antenne énumérés ci-dessous et ayant un gain admissible maximal et l'impédance requise pour chaque type d'antenne. Les types d'antenne non inclus dans cette liste, ou dont le gain est supérieur au gain maximal indiqué, sont strictement interdits pour l'exploitation de l'émetteur.

Avertissement:

Le dispositif fonctionnant dans la bande 5150-5250 MHz est réservé uniquement pour une utilisation à l'intérieur afin de réduire les risques de brouillage préjudiciable aux systèmes de satellites mobiles utilisant les mêmes canaux.

Remark :

Antenna Information :

2.4G N-Type Antenna @ 11dBi / PIFA; 5dBi / Dipole

5G N-Type Antenna @ 14dBi / PIFA; 7dBi / Dipole

Europe – EU Declaration of Conformity

This device complies with the essential requirements of the R&TTE Directive 1999/5/EC.

The following test methods have been applied in order to prove presumption of conformity with the essential requirements of the R&TTE Directive 1999/5/EC:

Radio:	EN 300 328, EN 301 893
EMC:	EN 301 489-1, EN 301 489-17
Safety:	EN 60950-1
RF Exposure:	EN 50385
Emissions:	EN 55022, EN 61000-3-2, EN 61000-3-3
Immunity:	EN 61000-4-2, EN 61000-4-3, EN 61000-4-4, EN 61000-4-5, EN 61000-4-6, EN 61000-4-11

This device is a 2.4 GHz and 5 GHz wideband transmission system (transceiver), intended for use in all EU member states and EFTA countries with the following restrictions:

In Italy the end-user should apply for a license at the national spectrum authorities in order to obtain authorization to use the device for setting up outdoor radio links and/or for supplying public access to telecommunications and/or network services.

The device may not be used in the 5 GHz spectrum unless the 5.725 - 5.875 GHz has been disabled.

This can be done through the Meraki Dashboard.

Česky (Czech)

Meraki, Inc. tímto prohlašuje, že tento wireless device je ve shodě se základními požadavky a dalšími příslušnými ustanoveními směrnice.

Dansk (Danish)

Undertegnede Meraki, Inc. erklærer herved, at følgende udstyr wireless device overholder de væsentlige krav og øvrige relevante krav i direktiv 1999/5/EF.

Deutsch (German)

Hiermit erklärt Meraki, Inc., dass sich das Gerät wireless device in Übereinstimmung mit den grundlegenden Anforderungen und den übrigen einschlägigen Bestimmungen der Richtlinie 1999/5/EG befindet.

Eesti (Estonian)

Käesolevaga kinnitab Meraki, Inc. seadme wireless device vastavust direktiivi 1999/5/EÜ põhinõuetele ja nimetatud direktiivist tulenevatele.

English

Hereby, Meraki, Inc., declares that this wireless device is in compliance with the essential requirements and other relevant provisions of Directive 1999/5/EC.

Español (Spanish)

Por medio de la presente Meraki, Inc. declara que el wireless device cumple con los requisitos esenciales y cualesquiera otras disposiciones aplicables o exigibles de la Directiva 1999/5/CE.

Ελληνική (Greek)

ΜΕ ΤΗΝ ΠΑΡΟΥΣΑ Meraki, Inc. ΔΗΛΩΝΕΙ ΟΤΙ wireless device ΣΥΜΜΟΡΦΩΝΕΤΑΙ ΠΡΟΣ ΤΙΣ ΟΥΣΙΩΔΕΙΣ ΑΠΑΙΤΗΣΕΙΣ ΚΑΙ ΤΙΣ ΛΟΙΠΕΣ ΣΧΕΤΙΚΕΣ ΔΙΑΤΑΞΕΙΣ ΤΗΣ ΟΔΗΓΙΑΣ 1999/5/ΕΚ.

Français (French)

Par la présente Meraki, Inc. déclare que l'appareil wireless device est conforme aux exigences essentielles et aux autres dispositions pertinentes de la directive 1999/5/CE.

Italiano (Italian)

Con la presente Meraki, Inc. dichiara che questo wireless device è conforme ai requisiti essenziali ed alle altre disposizioni pertinenti stabilite dalla direttiva 1999/5/CE.

Latviski (Latvian)

Ar šo Meraki, Inc. deklarē, ka wireless device atbilst Direktīvas 1999/5/EK būtiskajām prasībām un citiem ar to saistītajiem noteikumiem.

Lietuvių (Lithuanian)

Šiuo Meraki, Inc. deklaruoja, kad šis wireless device atitinka esminius reikalavimus ir kitas 1999/5/EB Direktyvos nuostatas.

Nederland (Dutch)

Hierbij verklaart Meraki, Inc. dat het toestel wireless device in overeenstemming is met de essentiële eisen en de andere relevante bepalingen van richtlijn 1999/5/EG.

Malti (Maltese)

Hawnhekk, Meraki, Inc., jiddikjara li dan wireless device jikkonforma mal-ħtigijiet essenzjali u ma provvedimenti oħrajn relevanti li hemm fid-Dirrettiva 1999/5/EC.

Magyar (Hungarian)

Alulírott, Meraki, Inc. nyilatkozom, hogy a wireless device megfelel a vonatkozó alapvető követelményeknek és az 1999/5/EC irányelv egyéb előírásainak.

Polski (Polish)

Niniejszym Meraki, Inc. oświadcza, że wireless device jest zgodny z zasadniczymi wymogami oraz pozostałymi stosownymi

Português (Portuguese)

Meraki, Inc. declara que este wireless device está conforme com os requisitos essenciais e outras disposições da Directiva 1999/5/CE.

Slovensko (Slovenian)

Meraki, Inc. izjavlja, da je ta wireless device v skladu z bistvenimi zahtevami in ostalimi relevantnimi določili direktive 1999/5/ES.

Slovensky (Slovak)

Meraki, Inc. týmto vyhlasuje, že wireless device splna základné požiadavky a všetky príslušné ustanovenia Smernice 1999/5/ES.

Suomi (Finnish)

Meraki, Inc. vakuuttaa täten että wireless device tyyppinen laite on direktiivin 1999/5/EY oleellisten vaatimusten ja sitä koskevien direktiivin muiden ehtojen mukainen.

Svenska (Swedish)

Härmed intygar Meraki, Inc. att denna wireless device står i överensstämmelse med de väsentliga egenskapskrav och övriga relevanta bestämmelser som framgår direktiv 1995/5/EG.



Professional installation instruction

Please be advised that due to the unique function supplied by this product, the device is intended for use with our interactive entertainment software and licensed third-party only. The product will be distributed through controlled distribution channel and installed by trained professional and will not be sold directly to the general public through retail store.

1. Installation personal

This product is designed for specific application and needs to be installed by a qualified personal who has RF and related rule knowledge. The general user shall not attempt to install or change the setting.

2. Installation location

The product shall be installed at a location where the radiating antenna can be kept 30cm from nearby person in normal operation condition to meet regulatory RF exposure requirement.

3. External antenna

Use only the antennas which have been approved by Meraki Inc. The non-approved antenna(s) may produce unwanted spurious or excessive RF transmitting power which may lead to the violation of FCC/IC limit and is prohibited.

4. Installation procedure

Please refer to the rest of this manual for the detail.

5. Warning

Please carefully select the installation position and make sure that the final output power does not exceed the limit set force in relevant rules. The violation of the rule could lead to serious federal penalty.

The following maximum Transmit powers should be observed during configuration:

Panel antenna:

802.11b:	21.99 dBm
802.11g:	21.96 dBm
802.11n 20 M:	24.93 dBm
802.11n 40 M:	24.71 dBm
802.11a 5180-5240 MHz:	5.91 dBm
802.11n 20 MHz 5180-5240 MHz:	8.68 dBm
802.11n 40 MHz 5180-5240 MHz:	8.90 dBm
802.11a 5745-5825 MHz:	19.3 dBm
802.11n 5745-5825 MHz:	21.95 dBm
802.11n 5745-5825 MHz:	21.84 dBm

Dipole antenna:

802.11b:	24.38 dBm
802.11g:	27.84 dBm
802.11n 20 M:	27.82 dBm
802.11n 40 M:	26.0 dBm
802.11a 5180-5240 MHz:	12.98 dBm
802.11n 20 MHz 5180-5240 MHz:	15.95 dBm
802.11n 40 MHz 5180-5240 MHz:	15.99 dBm
802.11a 5745-5825 MHz:	25.89 dBm
802.11n 5745-5825 MHz:	28.05 dBm
802.11n 5745-5825 MHz:	28.9 dBm

At these levels the panel antenna can be used only on point to point application. Point to multi-points is not allowed, and may require further reductions to meet local regulations.

Instructions d'installation professionnelle

Veillez noter que l'appareil étant dédié à une fonction unique, il doit être utilisé avec notre logiciel propriétaire de divertissement interactif. Ce produit sera proposé par un réseau de distribution contrôlé et installé par des professionnels; il ne sera pas proposé au grand public par le réseau de la grande distribution.

1. Installation

Ce produit est destiné à un usage spécifique et doit être installé par un personnel qualifié maîtrisant les radiofréquences et les règles s'y rapportant. L'installation et les réglages ne doivent pas être modifiés par l'utilisateur final.

2. Emplacement d'installation

En usage normal, afin de respecter les exigences réglementaires concernant l'exposition aux radiofréquences, ce produit doit être installé de façon à respecter une distance de 30 cm entre l'antenne émettrice et les personnes.

3. Antenne externe

Utiliser uniquement les antennes approuvées par le fabricant. L'utilisation d'autres antennes peut conduire à un niveau de rayonnement essentiel ou non essentiel dépassant les niveaux limites définis par FCC/IC, ce qui est interdit.

4. Procédure d'installation

Consulter le manuel d'utilisation.

5. Avertissement

Choisir avec soin la position d'installation et s'assurer que la puissance de sortie ne dépasse pas les limites en vigueur. La violation de cette règle peut conduire à de sérieuses pénalités fédérales.

www.meraki.com
660 Alabama St.
San Francisco, California 94110
Phone: +1 415 632 5800
Fax: +1 415 632 5890